

## SERVICE VISION SCORPIO ARM



The Scorpio Arm is a different concept of Camera Car. With it we can do camera movements from a car controlled from inside driving at high speed and having images of more stables, dynamics, and with all safety measures for the members of the team.

<i>Crane Lengths</i>	12'	14'
Vehicle Height	1.75m/ 5' 9"	1.75m/ 5' 9"
Crane Length from Front to Pivot	3.6m/ 12'	4.3m/ 14'
Total Crane Length	3.6m/ 18' 6"	6.6m/ 21' 6"
Weight without counterweights	219 KG/ 482 LBS	227 KG/ 500 LBS
Max weight with counterweights (10 weight)	369 KG/ 813 LBS	407 KG/ 897.3 LBS
Max underslung Load	70 KG/ 154.3 LBS	70 KG/ 154.3 LBS
<b><i>Max Height of Crane (Underslung)</i></b>		
Front	4.4m/ 14' 5"	4.7m/ 15' 4"
Rear	4.4m/ 14' 5"	4.7m/ 15' 4"
Side	4.4m/ 14' 5"	4.7m/ 15' 4"

### ***The Set Up***

Scorpio Arm kit comes complete with HD monitors inside the car which are linked up to a record and playback facility. The kit includes a talk-back system that consists of both 6x internal and 4x external communication devices, the 4x external devices are Motorola GP328 walkie talkies that can be used by the 'hero car' driver and location coordinators.

**Mercedes ML63 AMG Specs:**

Horsepower	518 HP
Maximum Torque	700 Nm
Vehicle Length:	16' 1"
Vehicle Width:	5' 9"
Vehicle Height:	7' 1"
Vehicle Length (Post & Beam):	18' 1"
Vehicle Height (Post & Beam):	6' 9"
Wheel Width:	6' 6"
Max Speed:	120+ km/h
Capacity:	5 Passengers + Driver

Mercedes Benz ML63 AMG is a logical extension of our high-performance camera car line. As modified by us, the ML is powerful, agile, and versatile. It comes to location in a dedicated enclosed transport, ready to go with minimal setup. As with all of our cars, the ML arrives complete with HD video monitors and front and rear intercoms.

***The Scorpio Arm works with highly Experienced Crews***

1x Scorpio Arm Operator

1x Precision Driver

1x Flighthead 6S / Ronin 2 Camera Operator

1x Flighthead / Ronin 2 Technician

***Package Includes***

-Service Vision Scorpio Arm

-Flighthead 6s / DJI Ronin 2

-Mercedes ML63 AMG Tracking Car

-Intercoms System (COMSTAR Eartec / Hollyland Solidcom C1)

-SmallHD High Bright Monitor 703 x2

-Atomos Shogun Connect 7" x2

-Sony PVMA170 17" Professional OLED Production Monitor x1

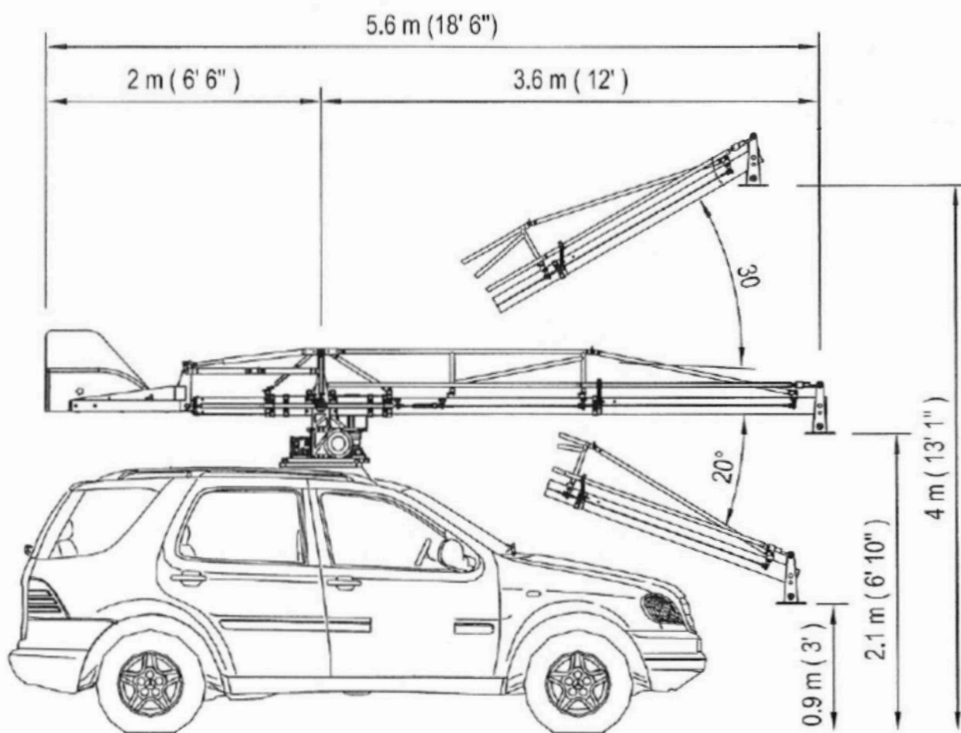
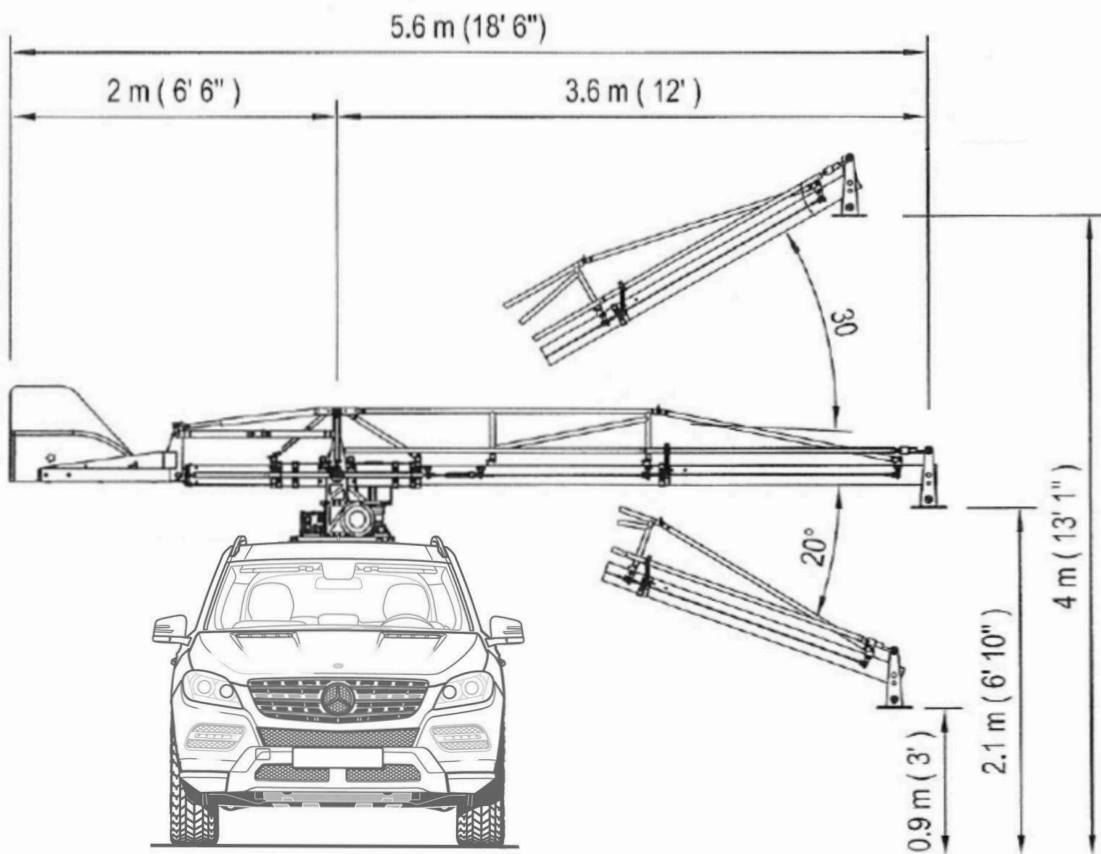

**Scorpio Arm 12' Configuration on Mercedes ML63**

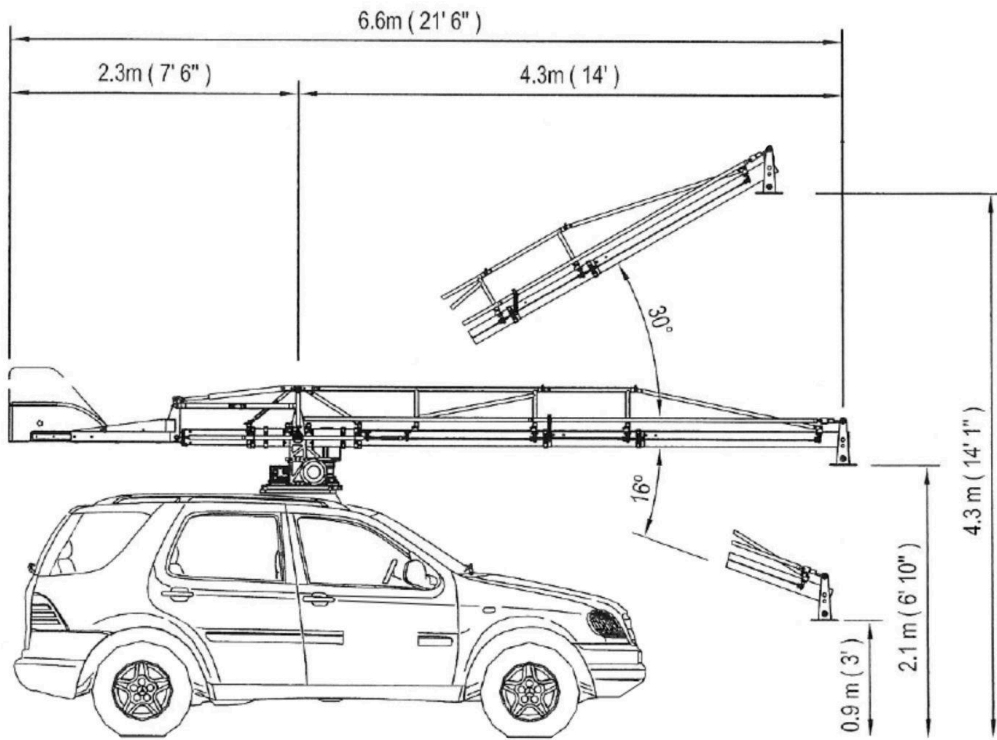
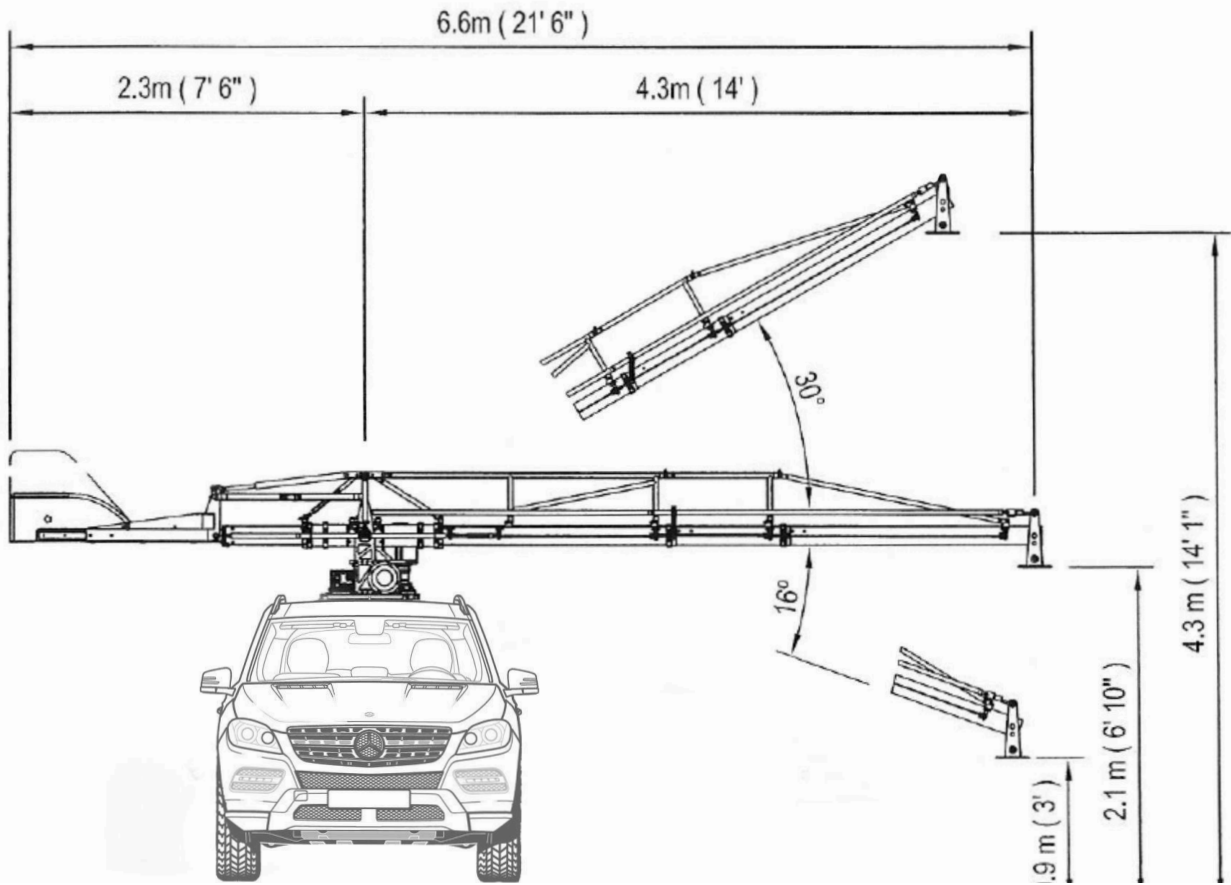

**Scorpio Arm 14' Configuration on Mercedes ML63**

## REMOTE HEAD

SPECS	DJI RONIN 2	FILMOTECHNIC FLIGHT HEAD 6S
WEIGHT	5KG / 11LBS	33KG / 72LBS
MAX PAYLOAD	13.6KG / 30LBS	55KG / 121LBS
RANGE	PAN 360°, TILT ±135°, ROLL ±30°	PAN 360°, TILT ±200°, ROLL ±270°
MAX SPEED	PAN 400°/sec, TILT/ROLL 360°/sec	360° PAN/ 2.2sec
MAX OP TEMP	-20 to 50 °C	-30°C to +40°C
CONTROLS	WHEELS/ JOYSTICK/ PAN BAR	WHEELS/ JOYSTICK/ PAN BAR

